



## SMART IOT-BASED FIRE PREVENTION AND FAULT DETECTION SYSTEM WITH AI-POWERED BATTERY MANAGEMENT FOR ELECTRIC VEHICLES

P. Suriya\*, S. Arokkiyaraja\*\*, P. Aswin Kumar\*\*, R. Aswinth\*\* & S. Bharanidharan\*\*

\* Assistant Professor, Department of Electrical and Electronics Engineering, Dhanalakshmi Srinivasan Engineering College (Autonomous), Perambalur, Tamil Nadu, India

\*\* UG Student, Department of Electrical and Electronics Engineering, Dhanalakshmi Srinivasan Engineering College (Autonomous), Perambalur, Tamil Nadu, India

**Cite This Article:** P. Suriya, S. Arokkiyaraja, P. Aswin Kumar, R. Aswinth & S. Bharanidharan, "Smart IoT-Based Fire Prevention and Fault Detection System With AI-Powered Battery Management for Electric Vehicles", International Journal of Engineering Research and Modern Education, Volume 11, Issue 1, January - June, Page Number 86-89, 2026.

**Copy Right:** © Crystal Pen Publication, 2026 (All Rights Reserved). This is an Open Access Article distributed under the Creative Commons Attribution License, which permits unrestricted use, distribution, and reproduction in any medium, provided the original work is properly cited.

**Type of Review:** Peer Reviewed as per |C|O|P|E| Guidance.

**Disclaimer:** The scholarly papers reviewed and published by Crystal Pen Publication, India, reflect the views and opinions of their respective authors and do not necessarily represent the views or opinions of Crystal Pen Publication. The publisher disclaims any responsibility for any harm, loss, or damage resulting from the use of the published content by any party.

**DOI:** <https://doi.org/10.5281/zenodo.19825855>

### Abstract:

Electric Vehicles (EVs) are rapidly emerging as a sustainable alternative to conventional transportation. However, battery-related faults such as overheating, overcharging, short circuits, and cell imbalance pose serious fire risks. This paper proposes a Smart IoT-Based Fire Prevention and Fault Detection System integrated with AI-powered Battery Management. The system utilizes multi-sensor monitoring to track temperature, voltage, current, and gas emissions in real time. Artificial Intelligence (AI) algorithms analyze the collected data to detect abnormal patterns and predict potential failures. When hazardous conditions are identified, the system generates instant alerts via mobile applications or SMS and triggers automatic safety actions such as relay cutoff and cooling mechanisms. A cloud-based dashboard provides real-time monitoring, historical data analysis, and predictive maintenance insights. The proposed system significantly enhances EV safety, reliability, and battery lifespan.

**Key Words:** Electric Vehicles, IoT, Battery Management System (BMS), Artificial Intelligence, Fire Prevention, Fault Detection, Thermal Runaway

### 1. Introduction:

Electric vehicles are gaining widespread adoption due to their environmental benefits, energy efficiency, and reduced operational costs. Among all EV components, the battery system plays a crucial role in determining performance, safety, and reliability. Lithium-ion batteries, widely used in EVs, are highly sensitive to operating conditions such as temperature, voltage fluctuations, and charging cycles. Improper conditions can lead to thermal runaway, resulting in fire hazards and system failure. To address these challenges, integrating Internet of Things (IoT) and Artificial Intelligence (AI) technologies provides an intelligent and proactive solution. IoT enables real-time monitoring, while AI enhances predictive analysis and decision-making capabilities.

### 2. Literature Survey:

S.No	Title & Authors	Year & Publication	Inference
1	Multi Sensor Monitoring System	2022 - IEEE Transactions on Energy Storage	Multi-sensor monitoring improves early detection of battery faults and reduces fire risks in EV systems.
2	IoT Based Intelligent Systems	2021 - IEEE IoT Conference	IoT enhances accessibility and enables remote monitoring of battery parameters in real time.
3	IoT Enabled BMS	2023 - Intelligent Technologies	Provides continuous data logging and improves safety through early fault detection alerts.
4	Thermal Management Study	2020 - Journal of Power Sources	Effective thermal management prevents overheating and reduces thermal runaway risks.
5	Advanced IoT Sensors	2024 - IEEE Sensors & IoT Applications	Improves real-time monitoring and enhances safety through continuous diagnostics.

### 3. Existing System:

Conventional EV Battery Management Systems (BMS) primarily monitor basic parameters such as voltage, current, and temperature. While these systems provide essential protection, they lack intelligence and predictive capabilities.

#### Limitations:

- No real-time remote monitoring
- No predictive fault detection
- No AI-based analysis
- Delayed response to critical conditions
- No automatic safety actions

These limitations increase the risk of battery failure and fire hazards.

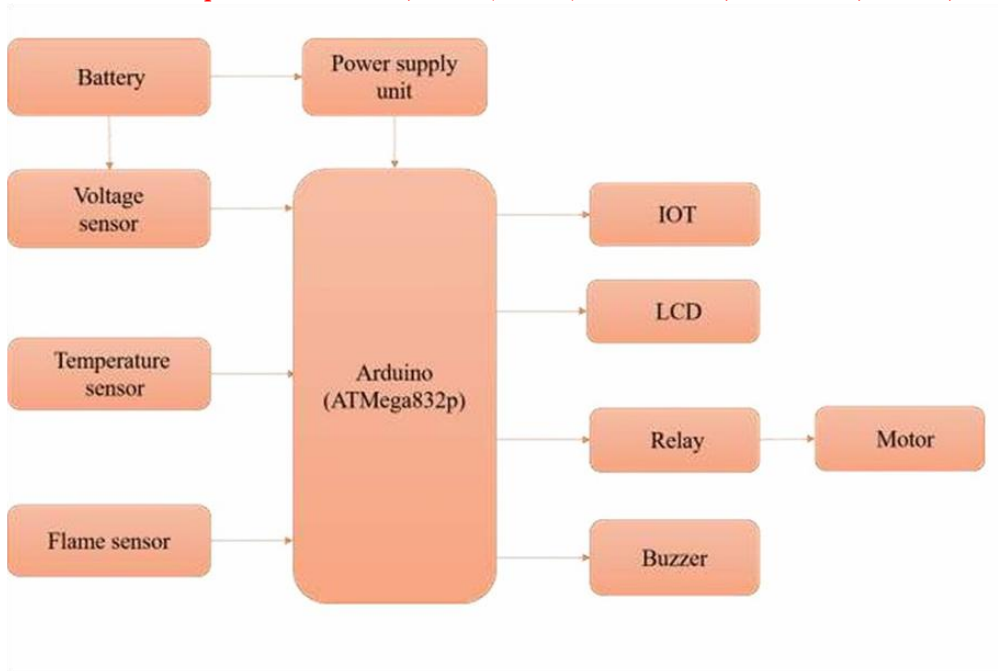

Figure 1: Existing System Block Diagram

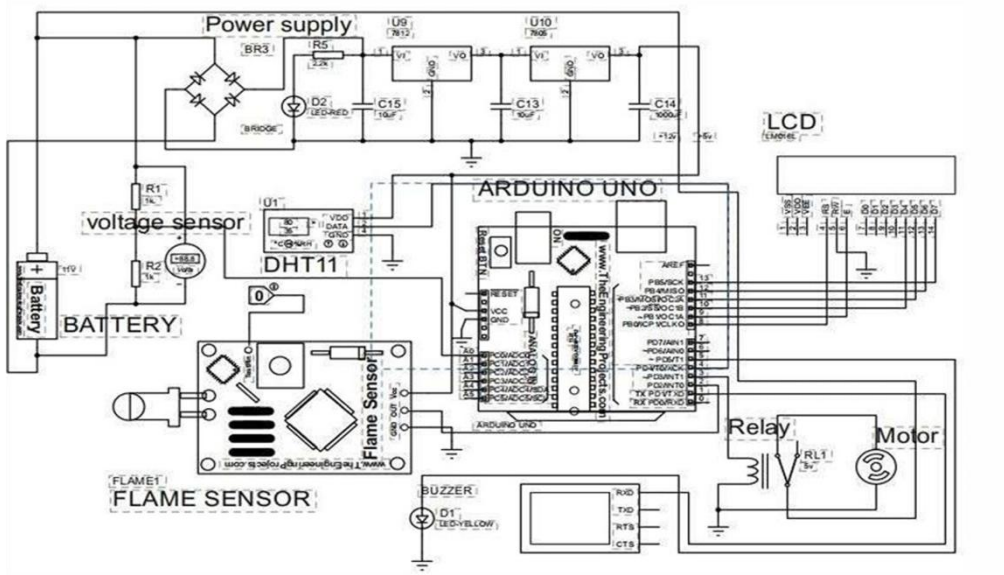

Figure 2: Proposed Circuit Diagram

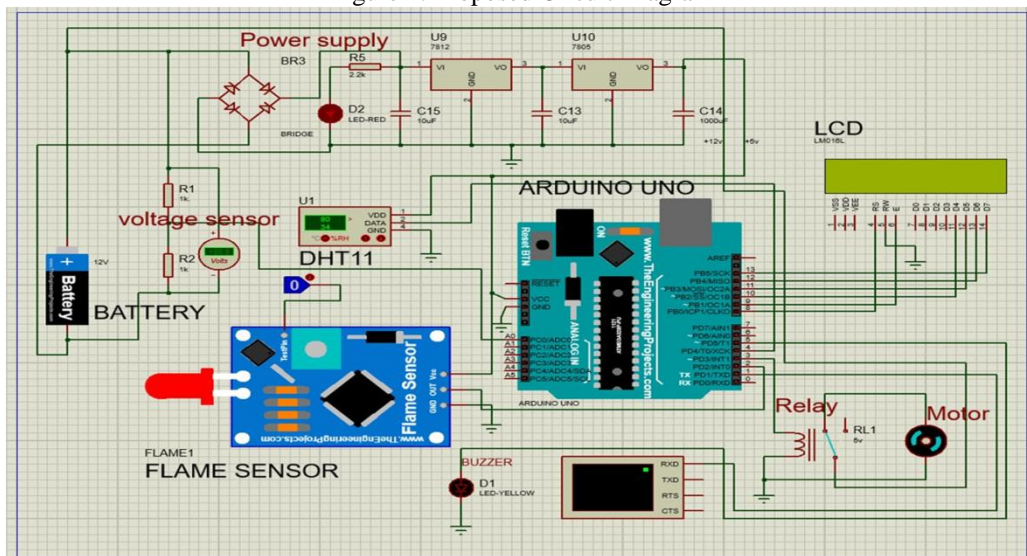

Figure 3: Simulation Diagram

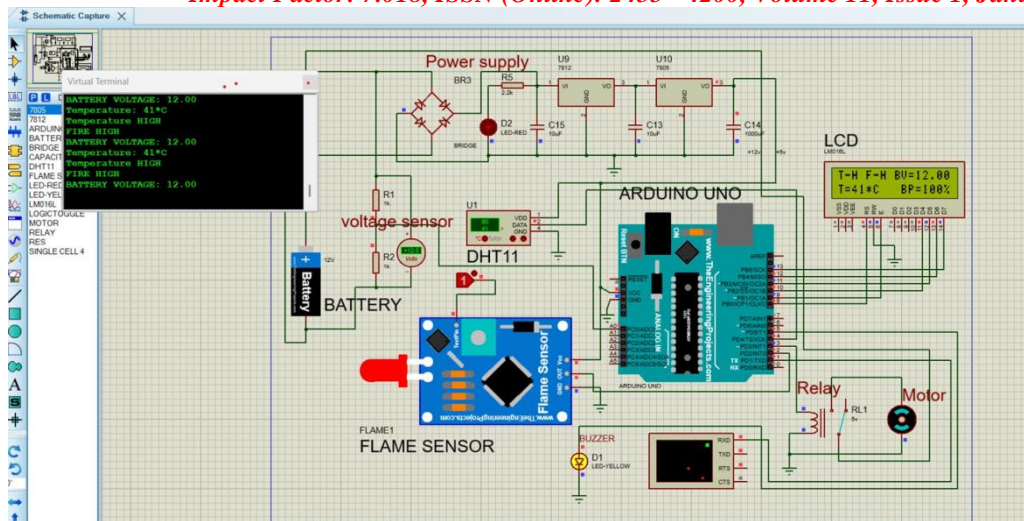

Figure 4: Simulation Output

#### 4. Proposed System:

The proposed Smart IoT-Based Fire Prevention and Fault Detection System is designed to provide an intelligent and proactive approach to battery safety in electric vehicles. The system integrates multiple sensors, including temperature, voltage, current, and gas sensors, to continuously monitor the real-time condition of the battery pack. These sensors collect critical data, which is processed by a microcontroller and transmitted to a cloud platform through IoT connectivity. This enables continuous remote monitoring and data logging, allowing users and operators to access battery status from anywhere.

A key feature of the proposed system is the incorporation of Artificial Intelligence algorithms for predictive analysis. The AI model analyzes historical and real-time data to identify abnormal patterns such as rapid temperature rise, voltage imbalance, or unusual gas emissions. By recognizing these early warning signs, the system can predict potential faults before they escalate into critical failures. This predictive capability significantly enhances the safety and reliability of the battery system.

In addition to monitoring and prediction, the system is equipped with automated safety mechanisms. When a hazardous condition is detected, the system can immediately trigger protective actions such as disconnecting the battery using a relay, activating cooling systems, or issuing alerts through mobile applications and SMS notifications. The cloud-based dashboard provides comprehensive visualization tools, including real-time graphs, historical data trends, and health indicators such as State of Charge (SOC) and State of Health (SOH). Overall, the proposed system ensures a robust, scalable, and intelligent solution for preventing fire accidents and improving battery performance in electric vehicles.

#### 5. Applications:

The proposed system has a wide range of applications across various sectors where battery safety and monitoring are critical. In electric vehicles such as scooters, motorcycles, cars, and auto-rickshaws, the system ensures continuous monitoring of battery health, helping to prevent overheating, overcharging, and potential fire hazards. It is particularly beneficial for EV fleet operators, as it allows centralized monitoring of multiple vehicles, enabling efficient management and early detection of faults to avoid unexpected breakdowns.

In battery swapping stations, the system plays a crucial role in ensuring that each battery is safe and in optimal condition before being issued to customers. By detecting internal faults and performance degradation, it improves operational safety and customer trust. Similarly, in EV charging stations, especially fast-charging setups, the system helps identify unsafe charging conditions and abnormal thermal behavior, thereby enhancing the safety of both the infrastructure and the users.

Beyond transportation, the system can be applied in industrial battery storage units, uninterruptible power supply (UPS) systems, and large-scale energy storage systems. It is also highly useful in renewable energy applications, such as solar and wind power storage, where lithium-ion batteries are widely used. By providing continuous monitoring and predictive maintenance, the system reduces the risk of thermal runaway, improves battery lifespan, and ensures reliable energy management across all these applications.

#### 7. Results and Discussion:

The implementation and simulation of the proposed system demonstrate its effectiveness in real-time battery monitoring and fault detection. The system successfully collects and processes data from multiple sensors, providing accurate measurements of key parameters such as temperature, voltage, and current. The integration of IoT technology ensures seamless data transmission to the cloud, where it is visualized through an interactive dashboard.

The AI-based analysis plays a significant role in improving system performance by identifying patterns that indicate potential faults. During testing, the system was able to detect abnormal conditions such as sudden temperature increases and voltage fluctuations well before they reached critical levels. This early detection capability allows timely intervention, preventing damage to the battery and reducing the risk of fire accidents.

Furthermore, the automated response mechanisms were observed to function effectively. When predefined threshold values were exceeded, the system triggered immediate actions such as relay cutoff and alert notifications. These responses significantly minimize the chances of thermal runaway and system failure. The cloud platform also provides valuable insights through historical data analysis, enabling predictive maintenance and long-term performance optimization. Overall, the results confirm that the proposed system enhances safety, reliability, and efficiency in electric vehicle battery management.

## 8. Conclusion:

This paper presents a comprehensive Smart IoT-Based Fire Prevention and Fault Detection System integrated with AI-powered Battery Management for electric vehicles. The proposed system addresses the critical safety challenges associated with lithium-ion batteries by combining real-time monitoring, intelligent analysis, and automated response mechanisms. Through the use of multi-sensor data acquisition and IoT connectivity, the system ensures continuous tracking of battery conditions and enables remote access to vital information.

The incorporation of Artificial Intelligence enhances the system's capability to predict potential failures and detect abnormal behavior at an early stage. This proactive approach significantly reduces the risk of thermal runaway, fire accidents, and unexpected battery failures. The automated safety actions further strengthen the system by ensuring immediate intervention during critical situations, thereby protecting both the vehicle and its users.

In addition to improving safety, the system contributes to better battery performance and extended lifespan through predictive maintenance and efficient energy management. The cloud-based platform provides valuable insights that support decision-making and system optimization. Overall, the proposed solution offers a reliable, scalable, and intelligent framework for next-generation electric vehicle safety systems. Future work can focus on enhancing AI models, integrating advanced thermal management techniques, and implementing the system in real-time commercial EV applications for broader impact.

## References:

1. Pawar, S., Mitkari, S., & Kodgire, S. (2025). Battery management system and fire protection in electric vehicles. *Journal of Control Systems and Converters*.
2. Kiasari, M. M., & Aly, H. H. (2024). Enhancing fire protection in electric vehicle batteries using thermal energy storage and machine learning. *Fire Journal*, 7(9), 296.
3. Anil, S., & Babu, S. (2024). IoT-based EV battery management system with charge monitoring and fire protection. *International Journal of Engineering Research and Science & Technology*, 20(4), 99-109.
4. Wang, Q., Ping, P., Zhao, X., Chu, G., Sun, J., & Chen, C. (2012). Thermal runaway caused fire and explosion of lithium-ion battery. *Journal of Power Sources*, 208, 210-224.
5. Feng, X., Ouyang, M., Liu, X., Lu, L., Xia, Y., & He, X. (2018). Thermal runaway mechanism of lithium-ion battery for electric vehicles: A review. *Energy Storage Materials*, 10, 246-267.
6. Li, Y., et al. (2018). Online state of health estimation for lithium-ion batteries using incremental capacity analysis. *Journal of Power Sources*, 373, 40-53.
7. Alam, M. M., Jagli, P., Ayman, M., & Akhtar, M. J. (2023). Electric vehicle battery management system with charge monitoring and fire protection. *International Education and Research Journal*.
8. Kaur, I., Singh, M., & Kasana, S. S. (2023). Early detection of fire in EV battery using machine learning approach. *IEEE Metro XRAINE Conference*.
9. Lalitha, M., Naik, R. A., Divya, A. L., & Sathvik, B. (2024). IoT-based battery management system for EVs with fault detection and fire prevention. *International Journal of Novel Research and Development*.
10. Liu, Z., et al. (2022). Experimental study on suppressing lithium-ion battery fires in electric vehicles. *Fire Safety Journal*, 129, 103562.